

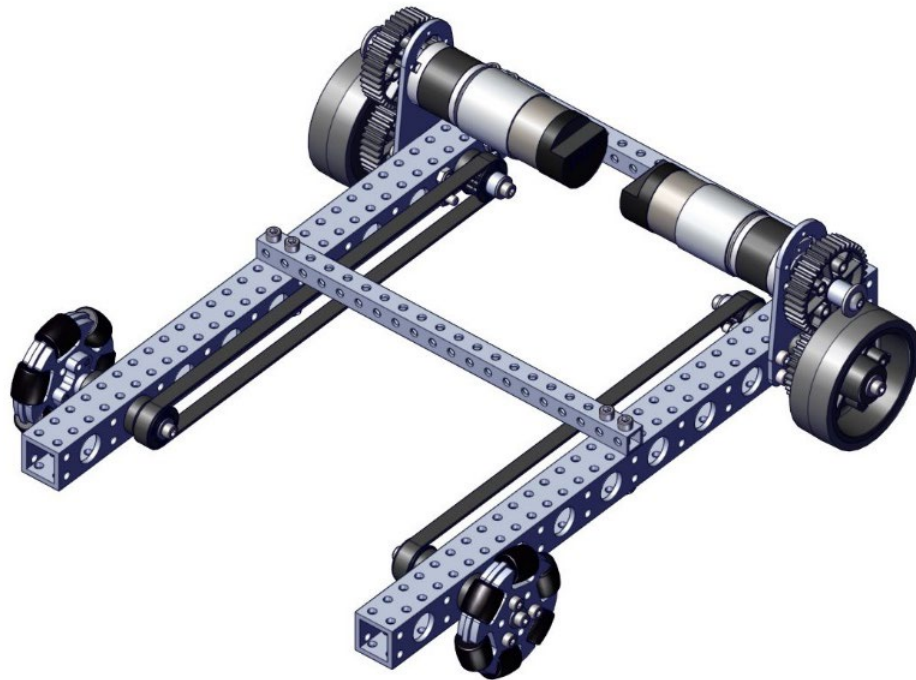

# Assembly Guide

**ROBITS**

## Starter Drive Base



## **AndyMark – Your Robot Parts Experts**

AndyMark, Inc. was founded in 2004 by Andy Baker and Mark Koors to design and sell unique mechanical parts for competition and educational robotics. Through their volunteer work at FIRST® events they identified a niche market and began designing and selling robotics components for FIRST® teams. AndyMark's staff has over 200 years of FIRST team experience, and provides staffing services to many robot competition events throughout the year. Our Kokomo, Indiana home provides a central location for quick distribution across North America, as well as international shipping to over 70 countries.

### **Welcome to ROBOTS!**

Robits is a building system for FIRST Tech Challenge teams, designed with accessibility in mind. Robits encourages rapid iteration and promotes development of critical thinking and problem solving.



The Robits system is designed to reduce complexity and enable robust builds. Parts align to a common 1/2" grid simplifying construction and allowing alignment of both structure and motion components. Optimized resolution of components simplifies the system while allowing teams to always have the parts they need to complete a build.

### **Additional Instructions Available**

For more product information, examples and guides check out **AndyMark.com**. For additional questions about any of our products contact us via e-mail at **support@andymark.com**, or call Toll-Free **877-868-4770**.

| <b>Required Tool List</b>              |                  |
|--|------------------|
| <b>AM Part Name</b>                    | <b>AM Part #</b> |
| Hex Driver, Ball End 2.5mm with Handle | am-3724          |
| Hex Driver, Ball End 3/32" with Handle | am-3173          |
| Hex Driver, Ball End 5/32" with Handle | am-2751          |
| 3/8 Combination Wrench                 | am-4961          |

## Starter Drive Base

| AM Part Name  | AM Part #    | Quantity |
|---|--------------|----------|
| Robits 0.5 x 0.5 x 10.0 Tube                          | am-5001-1000 | 2        |
| Robits 1.0 x 1.0 x 15.5 Tube                          | am-5002-1550 | 2        |
| NeveRest Orbital - 19.2                               | am-3637b     | 2        |
| Robits 80-100T Motor Mount                            | am-5017      | 2        |
| 6mm D to 375IN Hex-Shaft Adapter                      | am-3444      | 2        |
| Robits Bushing for 375 Hex                            | am-5021      | 8        |
| 121T Belt (605-5m-09)                                 | am-4959      | 2        |
| 14 Tooth 0.375 in. Hex Bore HTD Pulley Half           | am-4960_half | 8        |
| 40 Tooth 20DP 0.375 in. Hex Bore Plastic Gear         | am-5020_40   | 4        |
| Robits 0.375 in. Hex Shaft 3 in. Long                 | am-5003-0300 | 2        |
| Robits 0.375 in. Hex Shaft 4 in. Long                 | am-5003-0400 | 2        |
| 3 in. Stealth Wheel (Gray)                            | am-4718_gray | 2        |
| 10-32 Nylock Jam Nut                                  | am-1063      | 16       |
| Screw, SHCS, 10-32 x 0500                             | am-1002      | 8        |
| Screw, SHCS, 10-32 x 1500                             | am-1014      | 8        |
| Screw, SHCS, 10-32 x 1750                             | am-1048      | 8        |
| M3-0.5 x 8 mm Socket Head Cap Screw with Thread Patch | am-1500      | 6        |
| #10 Steel Washer                                      | am-1026      | 8        |
| Spacer, 0.430 ID x 0.500 OD x 0.250 Long Aluminum     | am-1698      | 6        |
| Spacer, 0.430 ID x 0.500 OD x 0.500 Long Aluminum     | am-1699      | 2        |
| 3" Omni Wheel (Single)                                | am-4967      | 2        |

## Omni Wheel Assembly (am-4967)

| AM Part Name              | AM Part #     | Quantity per Wheel | Quantity per Drive Base |
|---------------------------|---------------|--------------------|-------------------------|
| Bushing                   | am-0050       | 12                 | 24                      |
| Dowel                     | am-1019       | 6                  | 12                      |
| Omni Roller               | am-0049a      | 6                  | 12                      |
| Outer Plate               | am-4967_outer | 2                  | 4                       |
| Inner Plate               | am-4967_inner | 1                  | 2                       |
| Hub                       | am-4967_hub   | 1                  | 2                       |
| Screw, SHCS, 10-32 x 0750 | am-1047       | 3                  | 6                       |

## Assemble Omni Wheels

1. Place two bushings (am-0050) into each roller (am-0049a). Each wheel will use 6 rollers.

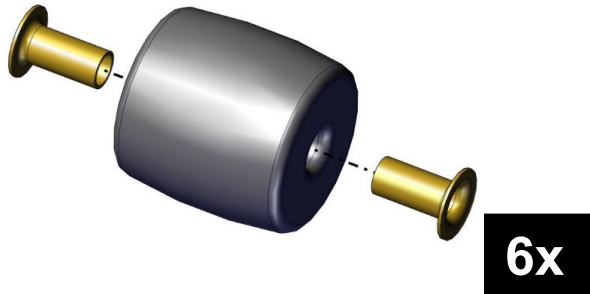

2. Place one dowel (am-1019) into each roller. Repeat for each of the 6 rollers per wheel.

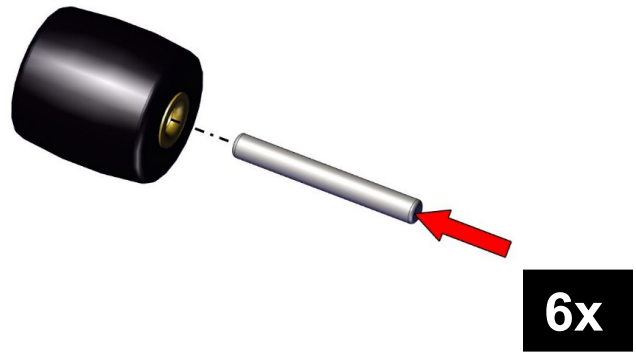

3. Stack an inner plate (am-4967\_inner) and an outer plate (am-4967\_outer) and place a roller assembly in between each spoke.

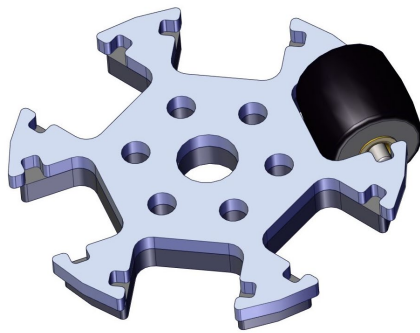

**Note:** The hub can be used as support under the plates to make it easier to place each of the rollers.

4. Cover the roller dowels with a second outer plate.

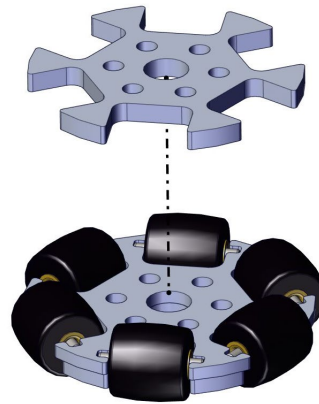

5. Fasten the stack to a hub (am-4967\_hub) with three 10-32 x 0750 inch screws (am-1047) in alternating holes.

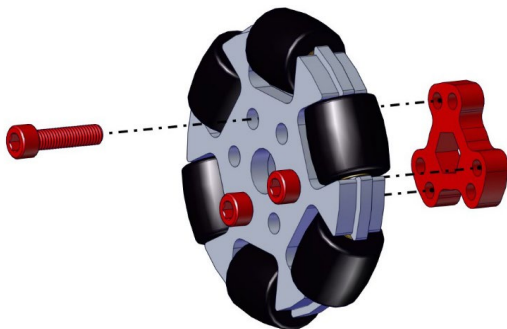

**Note:** A 3/8 shaft can be used to help align the center hole while tightening screws

6. Repeat steps 1-5 to build two wheels for the starter chassis.

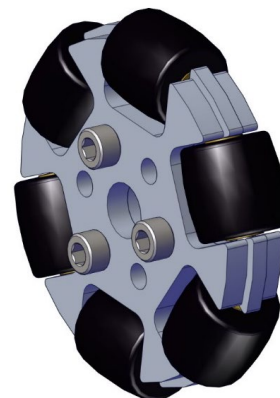

## Assemble Drive Modules

The Robits drive base has a module for each side. Ensure both a **left** and **right** version are built.

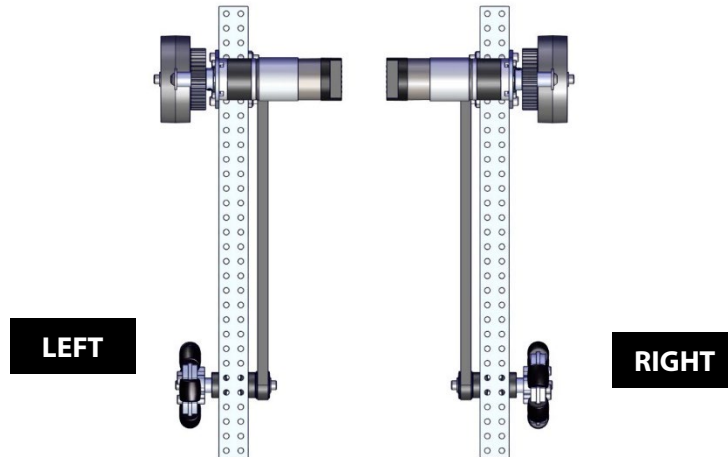

1. Install one 80-100T Motor Mount (am-5017) to the outside of the Robits 1.0 x 1.0 x 15.5 Tube (am-5002-1550) using four 10-32 x 1500 inch screws (am-1014) and four 10-32 nylock nuts (am-1063).

**Note: RIGHT Version Shown**

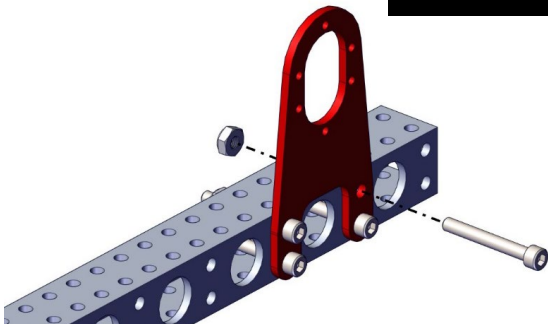

2. Install one NeveRest Orbital 19.2 gearmotor (am-3637b) to the Motor Mount plate using three M3-0.5 8mm patched screws (am-1500) in the lower three mounting holes.

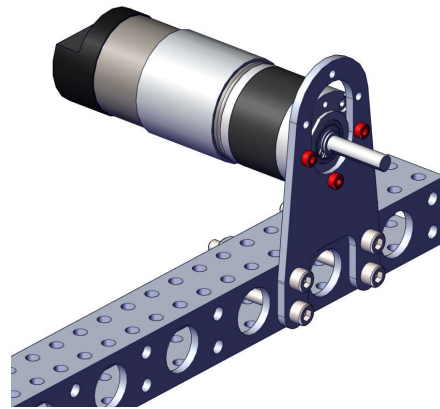

3. Place one 6mm to 375 Hex adapter (am-3444) on the motor shaft and secure to the shaft by tightening the set screw in the adapter.

**Note: Washer and screw from adapter will be used in step 5.**

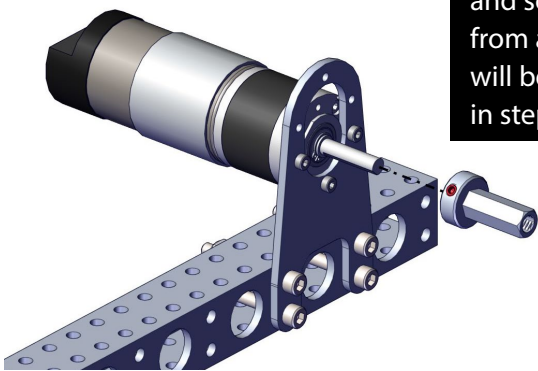

4. Place one 40T gear (am-5020\_40) on the adapter shaft.

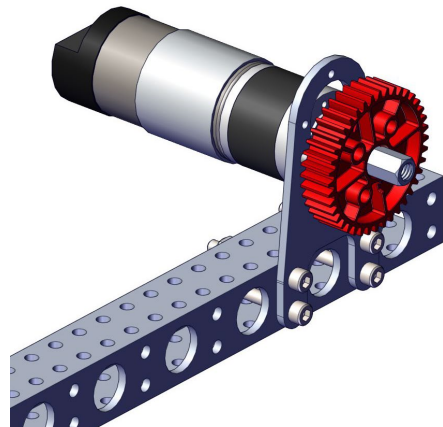

5. Place a ½ inch shaft spacer (am-1699) on the adapter shaft and retain with the washer and screw provided with the adapter.

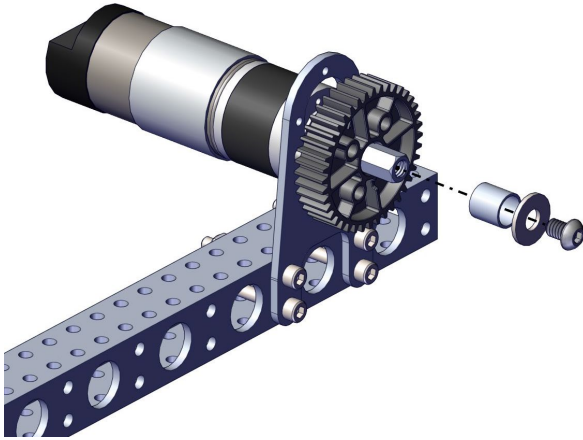

6. Insert two bushings (am-5021) into the tube under the motor mount.

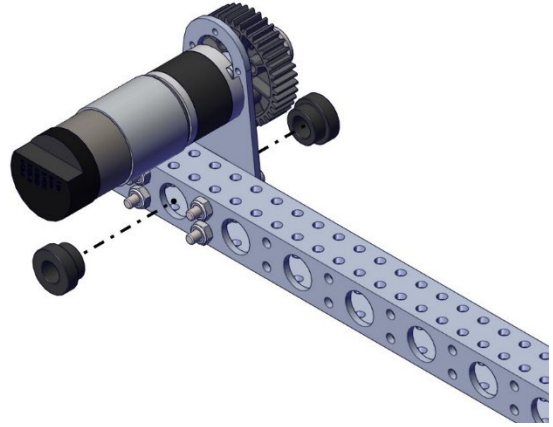

7. Install one 10-32 x 0500 inch screw (am-1002) with one #10 washer (am-1026) into the end of one 4 inch shaft (am-5003-0400).

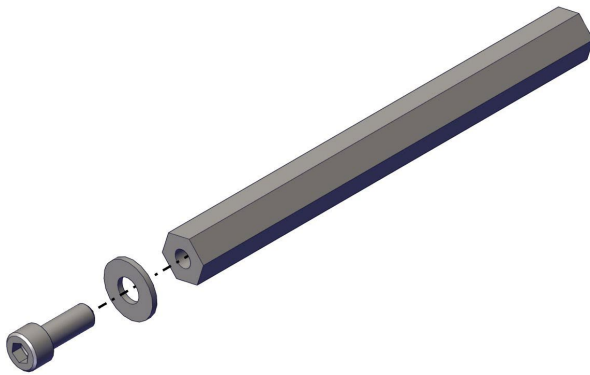

8. Put together two pulley halves (am-4960\_half) to create a pulley.



9. Add a ¼ inch shaft spacer (am-1698) and insert shaft assembly through the two 14T pulley halves and through the previously installed bushings in the tube.

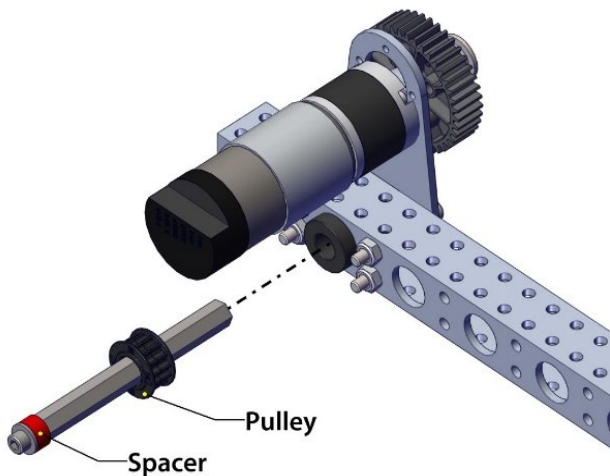

10. Slide one ¼ inch shaft spacer (am-1698) on the shaft from the outside and follow it with one 40T gear (am-5020\_40).

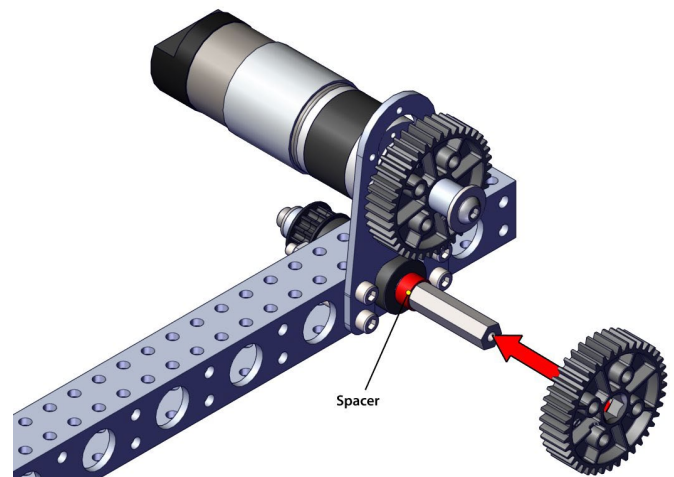

11. Add a 3 inch stealth wheel (am-4718\_gray) to the shaft. Retain the wheel with one 10-32 x 0500 inch screw (am-1002) with one #10 washer (am-1026).

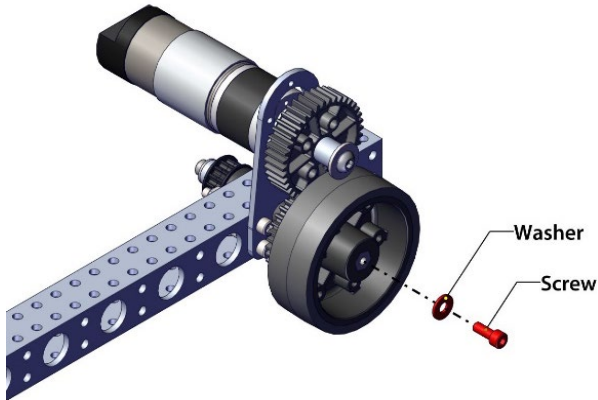

12. Insert two bushings (am-5021) into the tube in the 2nd hole from the end opposite the motor.

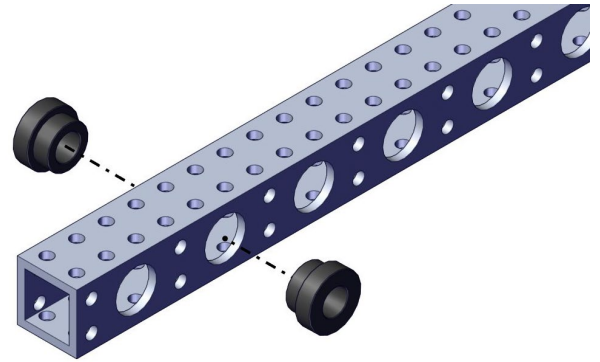

13. Install one 10-32 x 0500 inch screw (am-1002) with one #10 washer (am-1026) into the end of one 3 inch shaft (am-5003-0300).

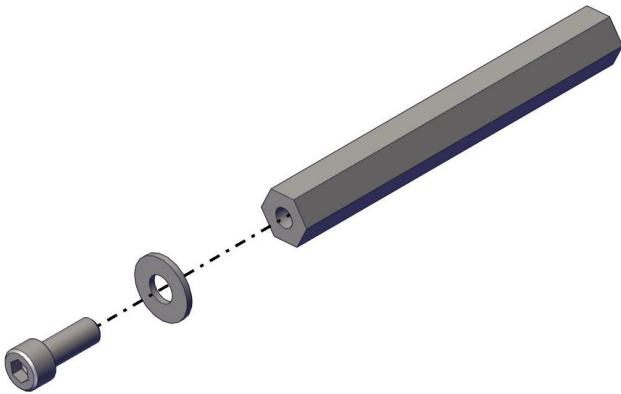

14. Place one 121T belt (am-4959) on to the motor side pulley and position two 14T pulley halves (am-4960\_half) on the opposite side.

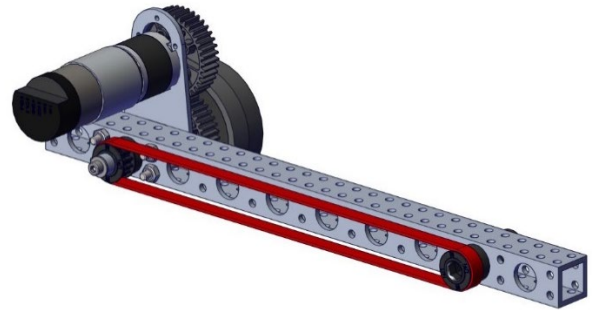

15. Insert the 3 inch shaft assembly through 14T pulley and previously installed bushings.

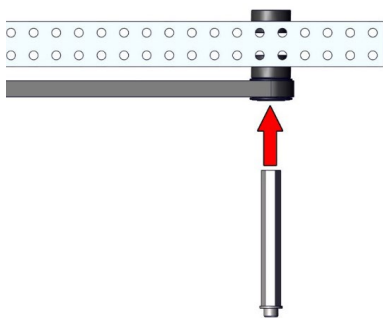

16. Slide one 1/4 inch shaft spacer (am-1698) on the shaft from the outside and follow it with one 3 inch omni wheel (am-4967).

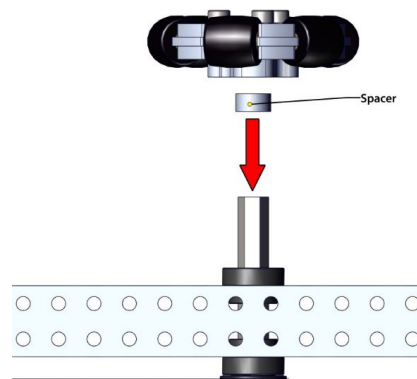

17. Retain wheel with one 10-32 x 0500 inch screw (am-1002) with one #10 washer (am-1026).

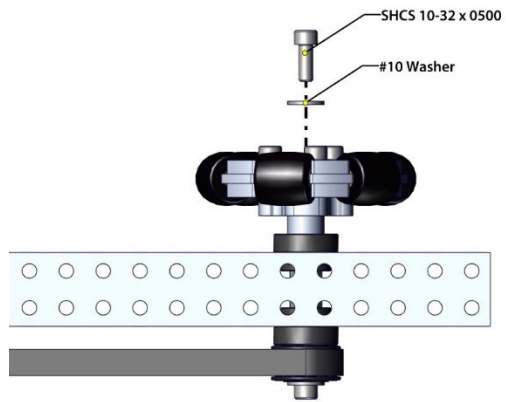

18. Repeat steps 1-17 in a mirror image to create a "left-handed" drive module.

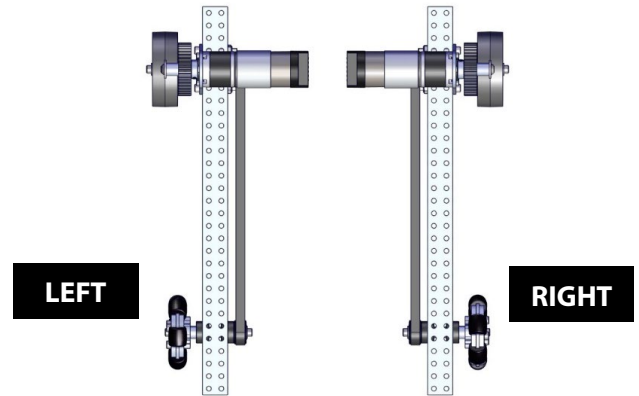

## Assemble Drive Base

Place two 0.5 x 0.5 x 10.0 tubes (am-5001-1000) on top of one of the drive modules and fasten with four 10-32 x 1750 inch screws (am-1048) and four 10-32 Nylock nuts (am-1063).

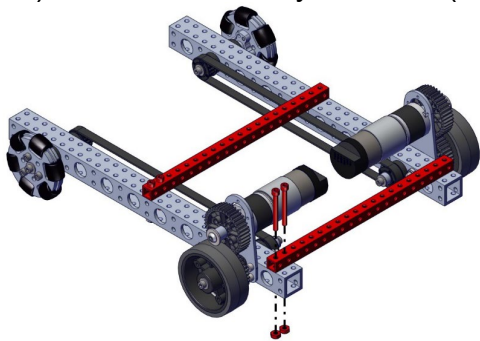

Align the other drive module with the existing inch 0.5 x 0.5 x 10.0 tubes and fasten with 10-32 x 1750 inch screws (am-1048) and 10-32 Nylock nuts (am-1063).

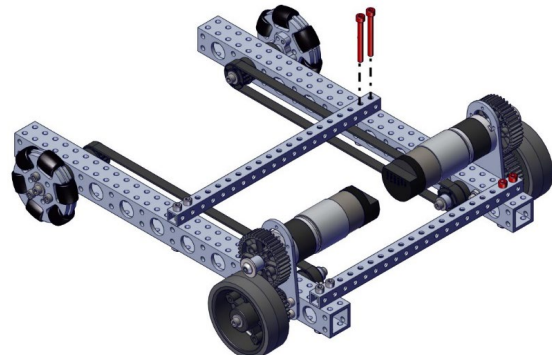

**Note:** Attach the tubes to the center hole pair and the second hole pair on the motor side.

The starter drive base is complete! Use this as a starting point and add on other parts, mechanisms, and electronics to create a complete robot.

